

POK offers a wide range of water / foam medium expansion tube with a durable, lightweight constant gallonage nozzle with flow reach up to 100 + feet with an expansion ration of 70. Made out of high-grade aluminum alloy with the trademarked NITUFF™ finish that gives 50 microns of PTFE impregnated anodized with and a aluminum tube in a red epoxy finish. Any hose line can benefit from these tubes and increase their performance and reach with water or with a foam solution that has become a necessity for many professional firefighters who are faced with higher risk.

### MEDIUM Tube Nozzles Medium Expansion Without shutoff

Flow (l/min or GPM)	Inlet	Code
200 to 240 l/mn	Female 1.5"	1305
400 to 475 l/mn	Female 1.5"	1307
800 to 950 l/mn *	Female 1.5"	1309
200 to 240 l/mn	Storz 1.5"	9029
400 to 475 l/mn	Storz 1.5"	9031
400 to 475 l/mn	Storz 2.5"	9032
800 to 950 l/mn *	Storz 2.5"	9034
15 to 20 GPM*	Female 1.0"	13740
50 to 60 GPM	Female 1.5"	13737
95 to 125 GPM	Female 1.5"	13738
200 to 250 GPM*	Female 2.5"	13739

(\*) Without gauge

### MEDIUM Tube Nozzles Medium Expansion With shutoff

Flow (l/min or GPM)	Inlet	Code
200 to 240 l/mn	Female 1.5"	1306
400 to 475 l/mn	Female 1.5"	1308
800 to 950 l/mn*	Female 1.5"	1756
200 to 240 l/mn	Storz 1.5"	9036
400 to 475 l/mn	Storz 1.5"	9038
400 to 475 l/mn	Storz 2.5"	9039
800 to 950 l/mn*	Storz 2.5"	9041
200 to 240 l/mn	Female 2.5"	13741
400 to 475 l/mn	Female 2.5"	13742
800 to 950 l/mn *	Male 2.5"	13743
15 to 20 GPM	Female 1.0"	13744
50 to 60 GPM	Female 1.5"	13745
95 to 125 GPM	Female 1.5"	13746
200 to 250 GPM *	Female 2.5"	13747

(\*) Without gauge

### LOW and MEDIUM Tube Nozzles With dual shutoff

Description	Code
Dual expansion @ 60 GPM - 200 l/m 1.5" inlet	20351
Dual expansion @ 95 GPM - 400 l/m 1.5" inlet	19722

MEDIUM EXPANSION FOAM TUBE



MEDIUM EXPANSION FOAM TUBE with shutoff

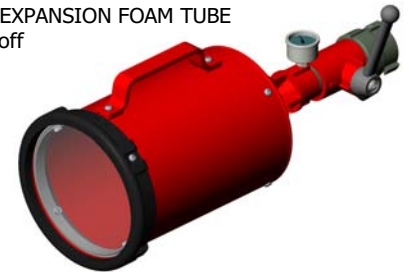

MEDIUM EXPANSION FOAM TUBE with shutoff and optional pistol grip



MEDIUM EXPANSION FOAM TUBE 250 GPM

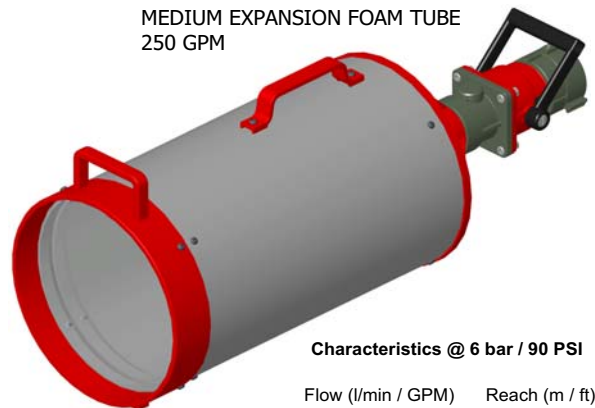

#### Characteristics @ 6 bar / 90 PSI

Flow (l/min / GPM)	Reach (m / ft)
200 / 50	8 / 26
400 / 95	12 / 40

