









Hydraulic Power Units



Special features

-  High oil flow in low and high pressure
-  Simultaneous hydraulic power units for the simultaneous operation of up to three tools
-  Automatic locking, flat face quick connect couplings
-  Optional with **Monocoupling**
-  Stable carrying frame with the option to upgrade to DIN-Standard frame
-  Large oil reservoirs equipped with gauge-glass
-  Rapid deployment equipment available: choice of front or side mount hose reels (2 reels, capacity is 20 to 40 m of high-pressure twin line hose per reel)
-  Can be upgraded and equipped with automatic manifolds for the permanent connection of up to four tools
-  Tool cradles available



Type LH-PU-MTO/C-G and -E

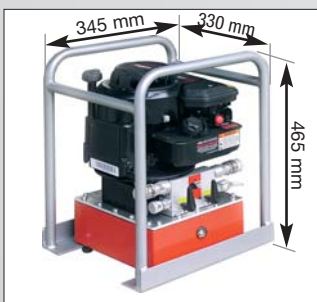

Operating pressure	630 - 720 bar
Oil flow/Pressure	2 x 2.4 l/min / 180 bar 2 x 0.7 l/min / 720 bar
Power unit	4-cycle gas engine
Power	2.15 kW
Oil tank (usable amount)	5 (3.5) l
Width/Depth/Height	330 / 345 / 465 mm
Weight	approx. 29 kg
Order-No. Type G	74680

Operating pressure	630 - 720 bar
Oil flow/Pressure	2 x 2.4 l/min / 180 bar 2 x 0.7 l/min / 720 bar
Power unit	electric AC motor 230 V/50 Hz
Power	1.85 kW
Oil tank (usable amount)	5 (3.5) l
Width/Depth/Height	330 / 345 / 465 mm
Weight	approx. 34 kg
Order-No. Type E	74670



Type LH-PU-MTO-G

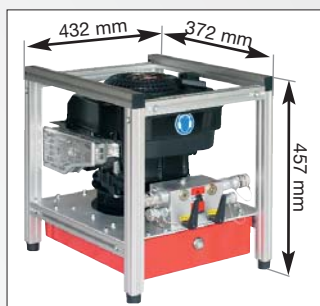

MTO power units can be equipped with automatic manifolds for the permanent connection of up to four tools!



Operating pressure	630 - 720 bar
Oil flow/Pressure	2 x 2.4 l/min / 180 bar 2 x 0.9 l/min / 720 bar
Power unit	4-cycle gas engine
Power	2.7 kW
Oil tank (usable amount)	7.5 (6.5) l
Width/Depth/Height	432 / 372 / 457 mm
Weight	approx. 33 kg
Order-No.	74500



Type LH-PU-MTO-E

Operating pressure	630 - 720 bar
Oil flow/Pressure	2 x 2.4 l/min / 180 bar 2 x 0.9 l/min / 720 bar
Power unit	electric AC motor 230 V/50 Hz
Power	1.85 kW
Oil tank (usable amount)	7.5 (6.5) l
Width/Depth/Height	432 / 372 / 457 mm
Weight	approx. 38 kg
Order-No.	74550

Type LH-PU-MTO-D with Diesel engine

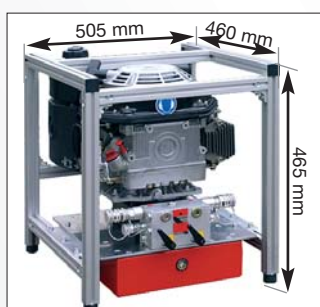

Operating pressure	630 - 720 bar
Oil flow/Pressure	2 x 2.4 l/min / 180 bar 2 x 0.9 l/min / 720 bar
Power unit	Diesel engine
Power	2.7 kW
Oil tank (usable amount)	7.5 (6.5) l
Width/Depth/Height	505 / 460 / 465 mm
Weight	approx. 52 kg
Order-No.	74560

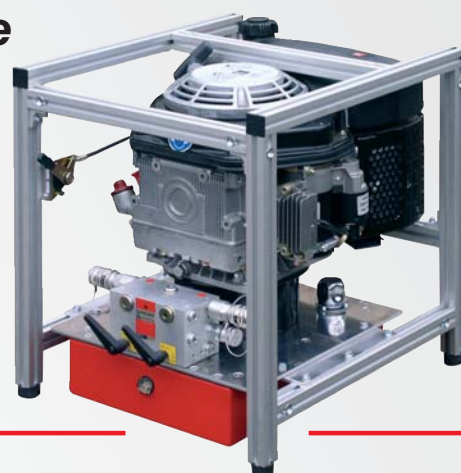

Hydraulic Power Units

LH-PU-TMTO-G



Operating pressure	630 - 720 bar
Oil flow/Pressure	3 x 2.4 l/min / 180 bar 3 x 0.6 l/min / 720 bar
Power unit	4-cycle gas engine
Power	3.5 kW
Oil tank (usable amount)	14.5 (11) l
Width/Depth/Height	505 / 430 / 457 mm
Weight	approx. 48 kg
Order-No.	74660



For the simultaneous operation of three tools!



LH-PU-STO-G

Operating pressure	630 - 720 bar
Oil flow/Pressure	3.6 l/min / 180 bar 0.9 l/min / 630 bar
Power unit	4-cycle gas engine
Power	2.15 kW
Oil tank (usable amount)	5 (3.5) l
Width/Depth/Height	285 / 372 / 440 mm
Weight	approx. 28 kg
Order-No.	74600

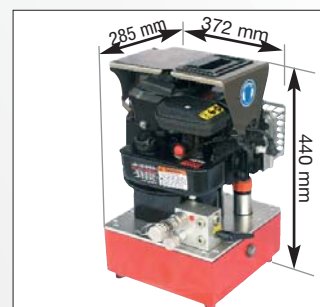

**Retrofittable to option ATO:
automatic manifold for two tools
with alternative operation**

LH-PU-STO-H

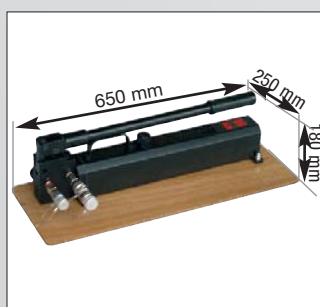

Operating pressure	630 - 700 bar
Oil flow/Hub	32 cm ³ 2.7 cm ³
Width	650 mm
Depth	250 mm
Height	180 mm
Weight	8.6 kg
Order-No.	67422

**Hand pump for
1 rescue tool**





**Battery operated, back-pack layout
for 1 rescue tool**



LH-PU-STO-BC

Operating pressure	up to 700 bar
Oil flow	0.7 l/min
Voltage of rechargeable battery	12 V DC
Operating time	approx. 40 min.
Oil tank (usable amount)	1.5 (1.4) l
Width/Depth/Height	380 / 180 / 270 mm
Weight	approx. 20 kg

Order-No. 74350

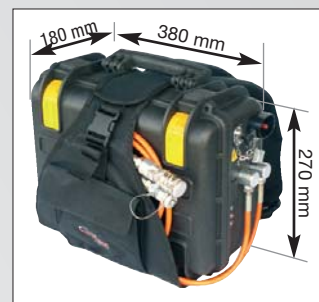

LH-PU-STO-BB



Operating pressure	up to 700 bar
Oil flow	0.7 l/min
Voltage of rechargeable battery	12 V DC
Operating time	approx. 40 min.
Oil tank (usable amount)	1.5 (1.4) l
Width/Depth/Height	180 / 180 / 530 mm
Weight	approx. 18 kg

Order-No. 74300

